

3D PRINTER SUBMITTAL FORM

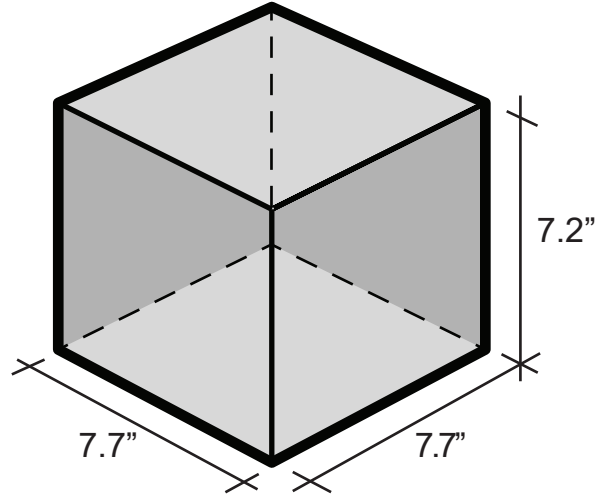

Name/800#: _____
 Email: _____
 Folder/File Name : _____
 Date submitted: _____
 Instructor/Course: _____

Printable Dimensions



PLA Color

<input type="checkbox"/> Red	<input type="checkbox"/> Blue	<input type="checkbox"/> Grey
<input type="checkbox"/> Yellow	<input type="checkbox"/> Purple	<input type="checkbox"/> Clear
<input type="checkbox"/> Orange	<input type="checkbox"/> White	<input type="checkbox"/> Other : Please Specify
<input type="checkbox"/> Green	<input type="checkbox"/> Black	

When do you need it? _____
 Fast and cheap Slow and pretty

KEEP IN MIND

If you're printing a simple geometry or series of simple things please provide a justification for why it needs to be 3-D Printed.

Student

Tips for ALL 3D Printing Projects

- Try to avoid printing basic cubes and simple massing prints
- The printers have a harder time keeping really thin prints clean [anything smaller than 1/16"]
- Make sure after you've modeled your print you change the UNITS to mm before bringing it to the assistant

Approval Lab Assistant

LA Name: _____
 Date approved: _____
 Estimated time: _____
 PLA in grams: _____
 Price (g x 0.10) _____
 Default Settings

Quality	Raft	Support	Layer Height	Infill	Notes
Normal	Yes 1 lyr	Touching Buildplate	.2mm	5-10%	

Printing Lab Assistant

Starting LA
 LA Name: _____
 Print Date : _____
 Start Time : _____
 Estimated End Time: _____

Ending LA
 Name: _____
 Print Date : _____
 End Time : _____
 Email sent

Reminder - ALWAYS remove the print bed from the printer before removing print